

MAS 650-S (IMO 2)

647 kVA (518kWe) / 1500 rpm 50 Hz. 753 kVA (603 kWe) / 1800 rpm 60 Hz

Technical Data

Engine designation	S6R-Z3MPTAW
No. of cylinders and configurations in	-line 6
Method of operation	4-stroke, direct-injected, turbocharged diesel engine with aftercooler
Bore, mm	170
Stroke, mm	180
Displacement	24.51
Compression ratio Crankshaft	14:1
Power HE Cooling	
at 1500 rpm, kW (hp)	545 (741)
at 1800 rpm, kW (hp)	635 (864)
Crankshaft Power KC Cooling	
at 1500 rpm, kW (hp)	515 (700)
at 1800 rpm, kW (hp)	595 (809)
Recommended fuel to conform to	ASTM No. 2-D
g/kWh at 1500 rpm	204 (100%)
g/kWh at 1800 rpm	208 (100%)

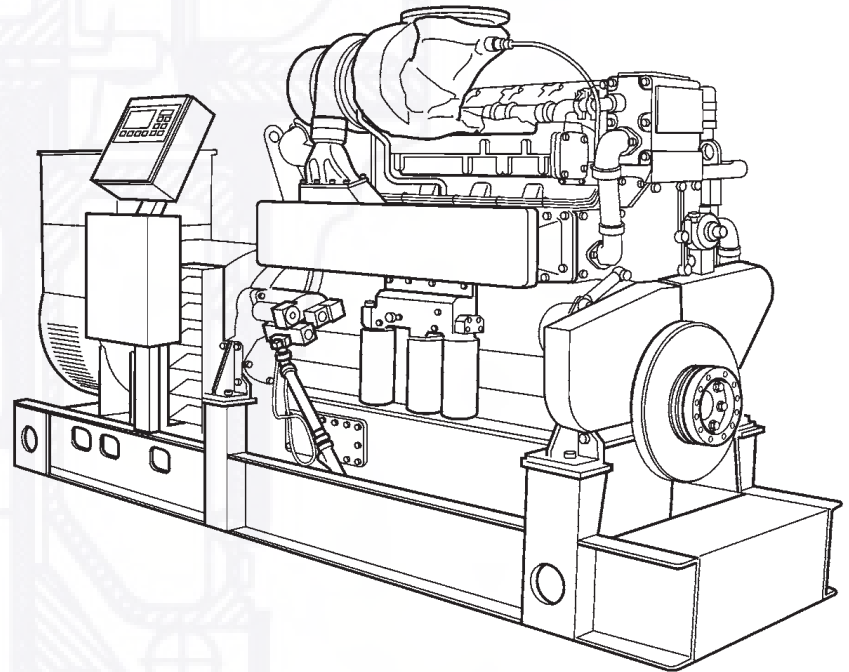

All data represent net performance with standard accessories such as fuel injection pump, water pump, L.O. pump and charging alternator under the conditions of 100kPa (750mm Hg), barometric pressure 300K (27°C) ambient temperature and 60% relative humidity.

Mitsubishi Auxiliary sets (MAS)

Mitsubishi Auxiliary Sets are the complete solution for a ship's on-board power requirements. You will not only get reliable marine diesels, well-matched generators and a monitoring system, but also a wide range of products and services to optimize your investment.

Each MAS is built in the factory fully adapted to the customer's requirements and comes complete and tested, ready for installation onboard.

The basis for the MAS is the smooth running and reliable marine diesel engines. Compact in design, they occupy less space in the engine room, and their good accessibility makes service and maintenance easy.

Engine

Mitsubishi engines are well balanced and have excellent emission performance, meeting all present and coming emission regulations, including IMO stage 2 and CCNR.

Mitsubishi's basic design in combination with Woodward governor and a modern electronic control system gives superior load acceptance and synchronizing capabilities, meeting all standards with good margin.

Generator

All the standard Gensets are equipped with a generator built by Newage Stamford. Stamford is the market leader in this power range and provides for worldwide service coverage. These generators are of a long proven design, based on years of experience of power generation for land-based and marine applications.