

NTA855-G4

Specification Sheet

Description

The Cummins NT-Series engines have been service proven through millions of hours of operation in some of the world's most demanding applications. The 14 litre, six-cylinder NTA855 has been engineered to handle higher injection pressures, with redesigned overhead arrangement, pistons, crankshaft and camshaft. A gear train with high contact ratio spur gears also eliminates unwanted thrust loads and reduces noise.

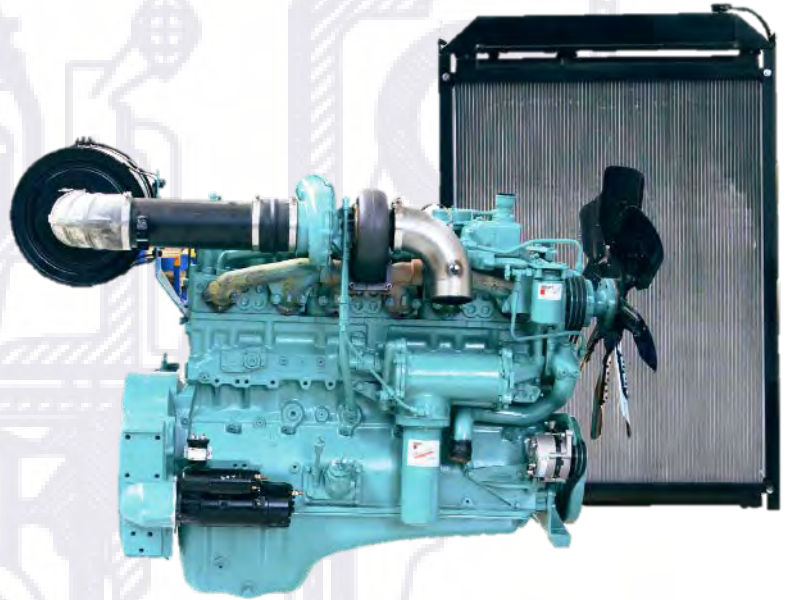

Features

Cylinder Block - Alloy cast iron with removable wet liners.

Cylinder Heads - Alloy cast iron. Each head serves two cylinders. Drilled fuel supply and return lines. Valve seat inserts are replaceable and corrosion resistant. Valve and crosshead guides are replaceable.

Cylinder Liners - Replaceable wet liners dissipate heat faster than dry liners and are easily replaced without reborring the block.

Fuel System - Cummins PT™ self adjusting system. Integral dual flyweight governor provides overspeed protection independent of main governor. Camshaft actuated fuel injectors give accurate metering and timing. Dual spin-on fuel filters.

Coolpac Integrated Design - Products are supplied complete with cooling package and air cleaner kit for a complete power package. Each component has been specifically developed and rigorously tested for G-Drive products, ensuring high performance, durability and reliability.

Service and Support - G-Drive products are backed by an uncompromising level of technical support and after sales service, delivered through a world class service network.

1500 rpm (50 Hz Ratings)

Gross Engine Output			Net Engine Output			Typical Generator Set Output					
Standby	Prime	Base	Standby	Prime	Base	Standby (ESP)		Prime (PRP)		Base (COP)	
kWm/BHP			kWm/BHP			kWe	kVA	kWe	kVA	kWe	kVA
351/471	317/425	272/365	337/451	307/411	262/351	320	400	292	365	245	306

Ratings Definitions

Emergency Standby Power (ESP): Applicable for supplying power to varying electrical load for the duration of power interruption of a reliable utility source. Emergency Standby Power (ESP) is in accordance with ISO 8528. Fuel Stop power in accordance with ISO 3046, AS 2789, DIN 6271 and BS 5514.

Limited-Time Running Power (LTP): Applicable for supplying power to a constant electrical load for limited hours. Limited-Time Running Power (LTP) is in accordance with ISO 8528.

Prime Power (PRP):

Applicable for supplying power to varying electrical load for unlimited hours. Prime Power (PRP) is in accordance with ISO 8528. Ten percent overload capability is available in accordance with ISO 3046, AS 2789, DIN 6271 and BS 5514.

Base Load (Continuous) Power (COP): Applicable for supplying power continuously to a constant electrical load for unlimited hours. Continuous Power (COP) in accordance with ISO 8528, ISO 3046, AS 2789, DIN6271 and BS 5514.

General Engine Data

Type	4 cycle, in-line, Turbo Charged
Bore mm	140 mm (5.5 in.)
Stroke mm	152 mm (6.0 in.)
Displacement Litre	14.0 litre (855 in. ³)
Cylinder Block	Cast iron, 6 cylinder
Battery Charging Alternator	55 amps
Starting Voltage	24 volt, negative ground
Fuel System	Direct injection
Fuel Filter	Spin-on fuel filters with water separator
Lube Oil Filter Type(s)	Spin-on full flow filter
Lube Oil Capacity (l)	38.6
Flywheel Dimensions	1/14

Coolpac Performance Data

Cooling System Design	Jacket Water After Cooled
Coolant Ratio	50% ethylene glycol; 50% water
Coolant Capacity (l)	45.0
Limiting Ambient Temp.**	54.7
Fan Power	11.6
Cooling System Air Flow (m ³ /s)**	7.6
Air Cleaner Type	Dry replaceable element with restriction indicator

** @ 13 mm H₂O

Weight & Dimensions

Length	Width	Height	Weight (dry)
mm	mm	mm	kg
2055	990	1535	1410

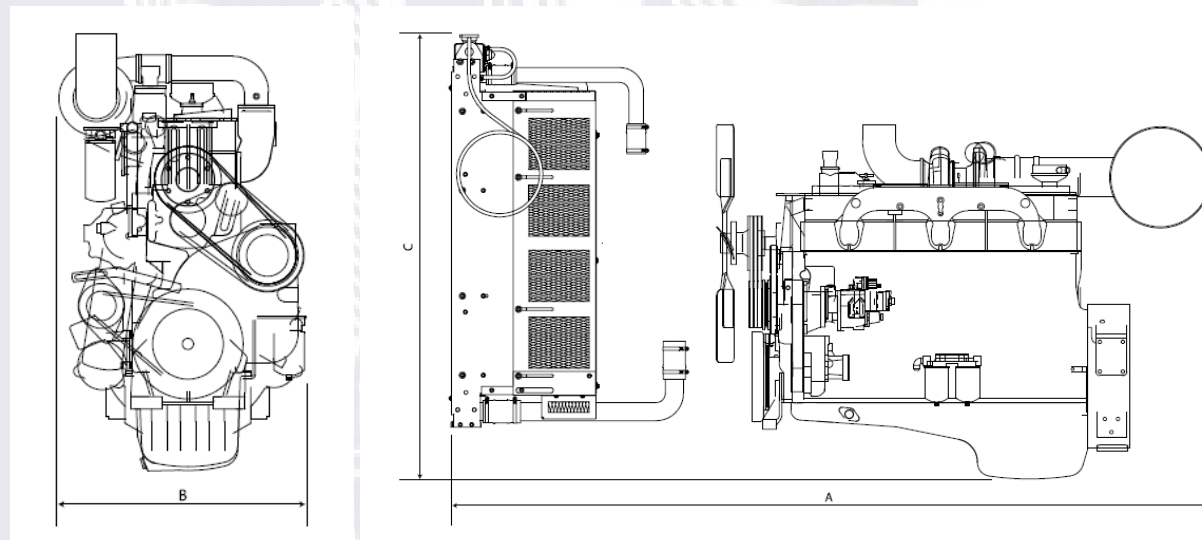

Fuel Consumption 1500 (50 Hz)

%	kWm	BHP	L/ph	US gal/ph
Standby Power				
100	351	471	84	21.8
Prime Power				
100	317	425	76	19.8
75	238	319	57	14.8
50	159	213	39	10.1
25	79	106	21	5.5
Continuous Power				
100	272	365	65	16.9