

TAD1241GE

VOLVO PENTA GENSET ENGINE

1500 rpm, 354 kW (481 hp) – 1800 rpm, 387 kW (526 hp)

The TAD1241GE is a powerful, reliable and economical Generating Set Diesel Engine built on the dependable in-line six design.

Durability & low noise

Designed for easiest, fastest and most economical installation. Well-balanced to produce smooth and vibration-free operation with low noise level.

To maintain a controlled working temperature in cylinders and combustion chambers, the engine is equipped with piston cooling. The engine is also fitted with replaceable cylinder liners and valve seats/guides to ensure maximum durability and service life of the engine.

Low exhaust emission

The state of the art, high-tech injection and charging system with low internal losses contributes to excellent combustion and low fuel consumption.

The TAD1241GE complies with EU Stage 2 and TA-Luft -50% exhaust emission regulations.

Easy service & maintenance

Easily accessible service and maintenance points contribute to the ease of service of the engine.

Technical description:

Engine and block

- Optimized cast iron cylinder block with optimum distribution of forces without the block being unnecessarily heavy.
- Wet, replaceable cylinder liners
- Piston cooling for low piston temperature and reduced ring temperature
- Tapered connecting rods for reduce risk of piston cracking
- Crankshaft induction hardened bearing surfaces and fillets with seven bearings for moderate load on main and high-end bearings
- Case hardened and nitrocarburized transmission gears for heavy duty operation
- Keystone top compression rings for long service life
- Viscous type crankshaft vibration dampers to withstand single bearing alternator torsional vibrations
- Replaceable valve guides and valve seats
- Over head camshaft and four valves per cylinder

Lubrication system

- Full flow oil cooler
- Full flow disposable spin-on oil filter, for extra high filtration
- The lubricating oil level can be measured during operation
- Gear type lubricating oil pump, gear driven by the transmission

Fuel system

- Non-return fuel valve
- Electronic Unit Injectors
- Fuel prefilter with water separator and water-in-fuel indicator / alarm
- Gear driven low-pressure fuel pump
- Fine fuel filter with manual feed pump and fuel pressure switch
- Fuel shut-off valve, electrically operated

Cooling system

- Air to air intercooler
- Coolant filter as standard
- Gear driven, maintenance-free coolant pump with high degree of efficiency

- Efficient cooling with accurate coolant control through a water distribution duct in the cylinder block. Reliable sleeve thermostat with minimum pressure drop

Turbo charger

- Efficient and reliable turbo charger
- Extra oil filter for the turbo charger

Electrical system

- Electrical Diesel Control III (EDCIII), an electronically controlled processing system which optimizes engine performance. It also includes advanced facilities for diagnostics and fault tracing
- Three different ways for the customer to connect his controls and instrument to the engine. CAN SAE J1939 interface, CIU (Control interface unit) and Stand alone connections.
- Sensors for oil pressure, oil temp, boost pressure, boost temp, coolant temp, fuel temp, water in fuel, fuel pressure and two speed sensors.



Features

- Maintained performance, air temp 40°C
- Tropical cooling system (55°C)
- Fully electronic with Volvo Penta EDC III
- Dual frequency switch (between 1500 rpm and 1800 rpm)
- High power density
- Emission compliant
- Low noise levels
- Gen Pac configuration

TAD1241GE

Technical Data

General

Engine designation.....	TAD1241GE	
No. of cylinders and configuration	in-line 6	
Method of operation.....	4-stroke	
Bore, mm (in.)	131 (5.16)	
Stroke, mm (in.)	150 (5.91)	
Displacement, l (in ³)	12.13 (740.2)	
Compression ratio	17.5:1	
Dry weight, kg (lb).....	1380 (3036)	
With Gen Pac, kg (lb)	1645 (3627)	
Wet weight, kg (lb)	1455 (3201)	
With Gen Pac, kg (lb)	1720 (3792)	

Performance

	1500 rpm	1800 rpm
with fan, kW (hp)	323 (439)	352 (479)
Prime Power	323 (439)	352 (479)
Max Standby Power	354 (481)	387 (526)

Lubrication system

	1500 rpm	1800 rpm
Oil consumption, liter/h (US gal/h)	0.11 (0.029)	0.12 (0.032)
Prime Power	0.11 (0.029)	0.12 (0.032)
Max Standby Power	0.12 (0.032)	0.13 (0.034)
Oil system capacity incl filters, liter.....	35	
Oil change intervals at specification		
VDS-2, h.....	600	
VDS, ACEA E3, h.....	400	
ACEA E1, E2, API CD, CF, CF-4, CG-4, h.....	200	

Fuel system

	1500 rpm	1800 rpm
Specific fuel consumption at		
Prime Power, g/kWh (lb/hph)		
25 %	216 (0.350)	231 (0.374)
50 %	199 (0.323)	208 (0.330)
75 %	195 (0.316)	200 (0.324)
100 %	198 (0.321)	202 (0.327)
Max Standby Power, g/kWh (lb/hph)		
25 %	211 (0.347)	225 (0.365)
50 %	197 (0.319)	203 (0.329)
75 %	195 (0.316)	200 (0.324)
100 %	199 (0.323)	203 (0.329)

Intake and exhaust system

	1500 rpm	1800 rpm
Air consumption at 27°C, m ³ /min (cfm)	23.5 (830)	28.0 (989)
Prime Power	23.5 (830)	28.0 (989)
Max Standby Power	25.0 (883)	29.0 (1024)
Max allowable air intake restriction, kPa (In wc)	5 (20.1)	
Heat rejection to exhaust,		
kW (BTU/min)		
Prime Power	250 (14217)	272 (15468)
Max Standby power	276 (15696)	306 (17402)
Exhaust gas temperature after turbine,		
°C (°F)		
Prime Power	490 (914)	465 (869)
Max Standby Power	505 (941)	490 (914)
Max allowable back-pressure in exhaust line, kPa (In wc)	10 (40.2)	
Exhaust gas flow, m ³ /min (cfm)	58 (2048)	66 (2331)
Prime power	58 (2048)	66 (2331)
Max Standby Power	63 (2225)	72 (2543)

Cooling system

	1500 rpm	1800 rpm
Heat rejection radiation from engine,		
kW (BTU/min)		
Prime Power	17 (967)	18 (1024)
Max Standby Power	18 (1024)	20 (1137)
Heat rejection to coolant kW (BTU/min)		
Prime Power	123 (6995)	139 (7905)
Max Standby Power	125 (7109)	143 (8132)
Fan power consumption, kW (hp)	9 (12)	15 (20)

Note! Not all models, standard equipment and accessories are available in all countries. All specifications are subject to change without notice. The engine illustrated may not be entirely identical to production standard engines.

Power Standards

The engine performance corresponds to ISO 3046, BS 5514 and DIN 6271. The technical data applies to an engine without cooling fan and operating on a fuel with calorific value of 42.7 MJ/kg (18360 BTU/lb) and a density of 0.84 kg/liter (7.01 lb/US gal), also where this involves a deviation from the standards. Power output guaranteed within 0 to

+2% att rated ambient conditions at delivery. Ratings are based on ISO 8528. Engine speed governing in accordance with ISO 3046/IV, class A1 and ISO 8528-5 class G3

Exhaust emissions

The engine complies with EU stage 2 emission legislation according to the Non Road Directive EU 97/68/EEC. The engine also complies with TA-luft -50% exhaust emission regulations.

Diesel&Gas Service
111524, Россия, г. Москва,
Проезд Фрезер, д.2, стр.107
Телефон: +7 (495) 775 01 27
E-mail: info@diesलगass.ru

Standard equipment

	Engine	Gen Pac
Engine		
Automatic belt tensioner	•	•
Lift eyelets	•	•
Flywheel		
Flywheel housing with conn. acc. to SAE 1	•	•
Flywheel for 14" flex. plate and flexible coupling	•	•
Vibration dampers	•	•
Engine suspension		
Fixed front suspension	•	•
Lubrication system		
Oil dipstick	•	•
Full-flow oil filter of spin-on type	•	•
By-pass oil filter of spin-on type	•	•
Oil cooler, side mounted	•	•
Low noise oil sump	•	•
Fuel system		
Fuel filters of disposable type	•	•
Electronic unit injectors	•	•
Pre-filter with water separator	•	•
Intake and exhaust system		
Air filter without rain cover	•	•
Air filter with replaceable paper insert	•	•
Air restriction indicator	•	•
Air cooled exhaust manifold	•	•
Connecting flange for exhaust pipe	•	•
Exhaust flange with v-clamp	•	•
Turbo charger, low right side	•	•
Crankcase ventilation	•	•
Cooling system		
Tropical radiator incl intercooler	• ¹⁾	•
Gear driven coolant pump	•	•
Fan hub	•	•
Thrust fan	—	•
Fan guard	—	•
Belt guard	—	•
Control system		
Engine Management System (EMS) with CAN-bus interface SAE J1939 and stand alone interface	•	•
Alternator		
Alternator 60A / 24 V	•	•
Starting system		
Starter motor, 6.0kW, 24 V	•	•
Connection facility for extra starter motor	•	•
Instruments and senders		
Temp.- and oil pressure for automatic stop/alarm 103°C	•	•
Other equipment		
Expandable base frame	—	•
Engine Packing		
Plastic warpping	•	•

¹⁾ must be ordered, see order specification - optional equipment
— optional equipment or not applicable
• included in standard specification

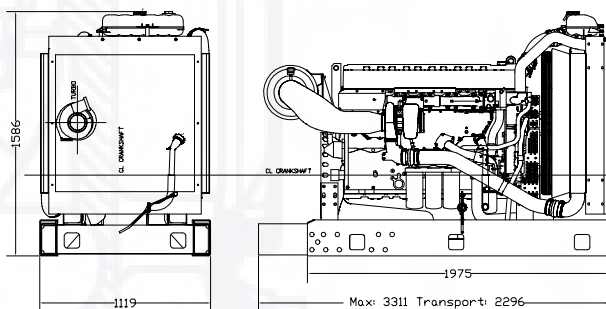

Rating Guidelines

PRIME POWER rating corresponds to ISO Standard Power for continuous operation. It is applicable for supplying electrical power at variable load for an unlimited number of hours instead of commercially purchased power. A10 % overload capability for governing purpose is available for this rating.

MAXIMUM STANDBY POWER rating corresponds to ISO Standard Fuel Stop Power. It is applicable for supplying standby electrical power at variable load in areas with well established electrical networks in the event of normal utility power failure. No overload capability is available for this rating.

1 hp = 1 kW x 1.36

Information

For more technical data and information, please look in the Generating Set Engines Sales Guide.