

TD720GE

VOLVO PENTA GENSET ENGINE

1500 rpm, 128 kW (174 hp) – 1800 rpm 134 kW (182 hp)

TD720GE

Turbocharged
Diesel fuel
Displacement indication (l)
Generation
Version
Generator drive
Emission controlled

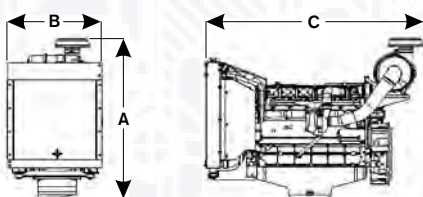

mm / in

A = 1240 / 48.8

B = 741 / 29.2

C = 1706 / 67.2

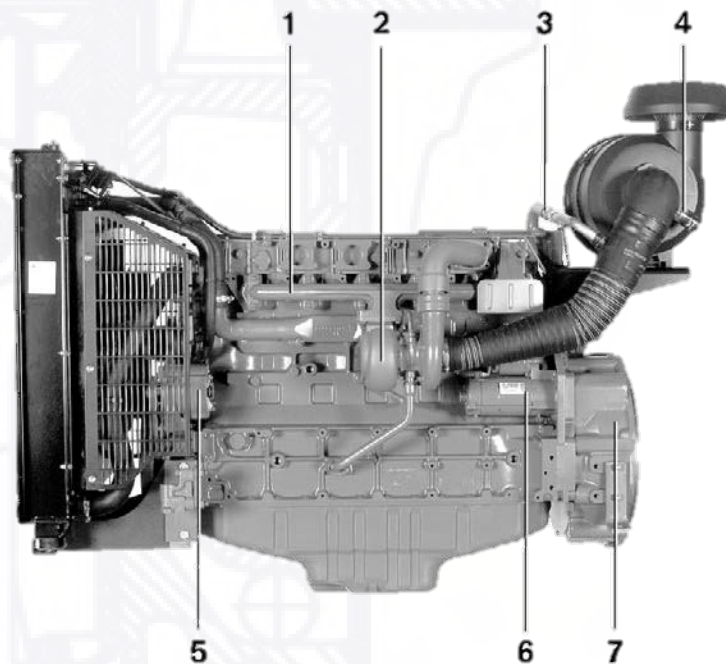

1. Exhaust manifold
2. Turbocharger
3. Closed loop crank case breather system
4. Air restriction indicator
5. Alternator
6. Starter motor
7. Flywheel housing SAE 2
8. Air filter
9. Speed governor
10. Stop solenoid
11. Oil filling
12. Oil cooler
13. Radiator cap
14. Engine transmission with PTO
15. Oil filter
16. Fuel filter
17. Radiator

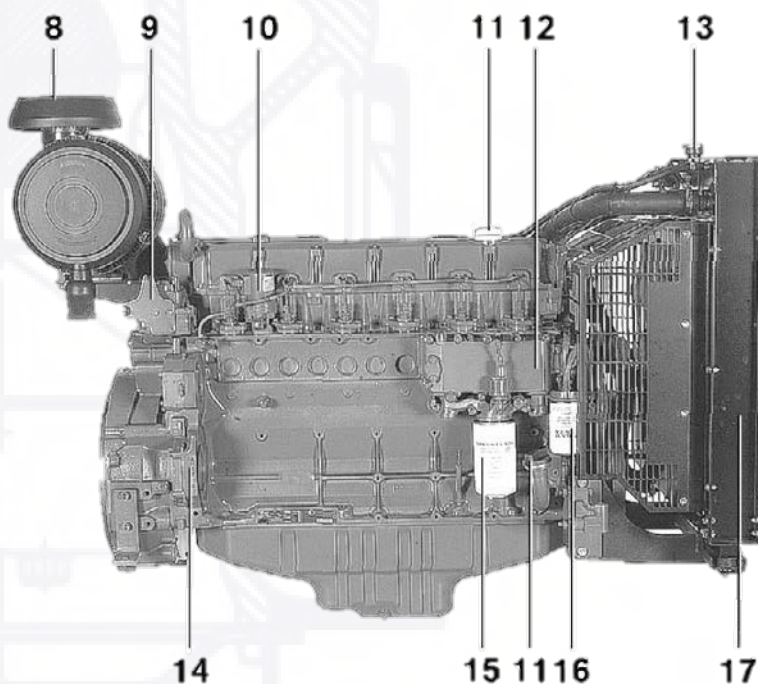

TD720GE

Technical Data

General

In-line four-stroke diesel engine with direct injection	Number of cylinders	6
Turbocharged and air to air intercooled	Displacement, total	7.15 liter / 4.36 in ³
Rotation direction, anti-clockwise viewed towards flywheel	Firing order	1-5-3-6-2-4
	Bore	108 mm / 4.25 in
	Stroke	130 mm / 5.12 in
	Compression ratio	17.5:1
Dry weight, kg / lb	Engine incl. cooling system	750 / 1653
Wet weight, kg / lb	Engine incl. cooling system	790 / 1742

TD720GE	Speed, rpm	1500	1800
Performance			
Prime Power without fan	kW / hp	117 / 159.1	123.0 / 167.2
Standby Power without fan	kW / hp	128.0 / 174.0	134.0 / 182.0
Fan power consumption			
Standard cooling system	kW / hp	2.5 / 3.4	4.3 / 5.8
Tropical cooling system	kW / hp	4.2 / 5.7	4.3 / 5.8
Mean piston speed	m/s / ft/sec	6.5 / 21.3	7.8 / 25.6
Effective mean pressure at Standby Power	MPa / psi	1.4 / 203	1.2 / 174
Max combustion pressure at Prime Power	MPa / psi	11.1 / 1610	10.5 / 1523
Total mass moment of inertia, J (mR ²)	kgm / lbft ²	3.09 / 73.3	

Lubrication system

Lubricating oil consumption at Standby Power	liter/h / US gal/h	0.01 / 0.02	0.1 / 0.02
Oil system capacity including filters	liter / Us gal	20 / 5.3	

Fuel system

Specific fuel consumption at			
50% of Prime Power	g/kWh / lb/hph	212 / 0.343	220 / 0.356
75% of Prime Power	g/kWh / lb/hph	208 / 0.337	212 / 0.343
100% of Prime Power	g/kWh / lb/hph	211 / 0.342	212 / 0.343

Intake and exhaust system

Air consumption at Standby Power (at 25 °C)	m ³ /h / cu.ft/h	485 / 17128	603 / 21295
Max allowable air intake restriction	kPa / In wc	3 / 12	
Heat rejection to exhaust at Standby Power	kW / BTU/min	108 / 6142	116 / 6597
Exhaust gas temperature after turbine at Standby Power	°C / °F	560 / 1040	505 / 941
Max allowable back-pressure in exhaust line	kPa / In wc	5 / 20	
Exhaust gas flow at Standby Power	m ³ /min / cfm	22.3 / 789	26.0 / 918

Cooling system

Heat rejection radiation from engine at Standby Power	kW / BTU/min	19.2 / 1092	20.0 / 1137
Heat rejection to coolant at Standby Power	kW / BTU/min	79.9 / 4544	83.8 / 4766
Fan power consumption			
standard cooling system	kW / hp	2.5 / 3.4	4.3 / 5.8
tropical cooling system	kW / hp	4.2 / 5.7	7.3 / 9.9

Power Standards

The engine performance corresponds to ISO 3046, BS 5514 and DIN 6271. The technical data applies to an engine without cooling fan and operating on a fuel with calorific value of 42.7 MJ/kg (18360 BTU/lb) and a density of 0.84 kg/liter (7.01 lb/US gal), also where this involves a deviation from the standards. Power output guaranteed within 0 to +2% at rated ambient conditions at delivery. Ratings are based on ISO 8528.

Engine speed governing in accordance with ISO 3046/IV, class A1 and ISO 8528-5 (G3 with electronic speed governor)

Exhaust emissions.

The engine exhaust emissions complies with EPA, CARB and TA-luft regulations.

Rating Guidelines

PRIME POWER rating corresponds to ISO Standard Power for continuous operation. It is applicable for supplying electrical power at variable load for an unlimited number of hours instead of commercially purchased power. A10 % overload capability is available for this rating.

STANDBY POWER rating corresponds to ISO Standard Fuel Stop Power. It is applicable for supplying standby electrical power at variable load in areas with well established electrical networks in the event of normal utility power failure. No overload capability is available for this rating.